

HPC | Compressed
Air Systems

Rotary Screw Compressors CSD / CSDX Series

With the world-renowned SIGMA PROFILE 

Free air delivery from 1.07 to 16.16 m³/min, Pressure 5.5 to 15 bar



CSD(X) Series

CSD/CSDX – Setting the standard

KAESER KOMPRESSOREN pushes the boundaries of compressed air efficiency once again with its latest generation of **CSD** and **CSDX** series rotary screw compressors. The value-added user benefits are immediately apparent just by taking a quick glance at the the completely redesigned compressor enclosure.

CSD/CSDX – Quadruple savings

Kaeser's new CSD and CSDX rotary screw compressor ranges provide significant energy savings in four ways: 1. new low-speed SIGMA PROFILE airends equipped with flow-optimised rotors have enabled specific power to be reduced by up to 6 % compared with previous models. 2. enjoy the benefits that premium efficiency IE3 drive motors have to offer (use of these motors will become mandatory in the EU from 01.01.2015). 3. Kaeser's 1:1 drive design eliminates the transmission losses associated with gear or V-belt driven systems, as the motor directly drives the airend. 4. The newly developed PC-based "SIGMA CONTROL 2" compressor controller enables compressor performance to be precisely matched to actual air demand thereby allowing additional energy savings.

Ease of maintenance ensures savings

There's much more to KAESER's latest system design than initially meets the eye: The new internal

Potential energy cost savings through heat recovery

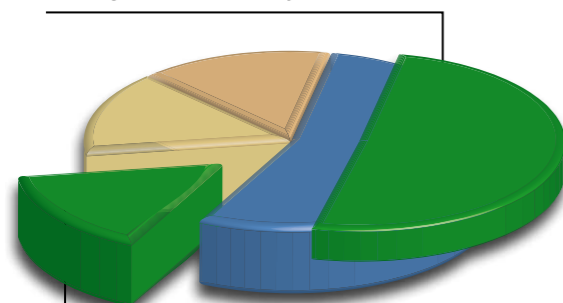

Energy cost savings through system optimisation



- Compressed air system investment
- Maintenance costs
- Energy costs
- Potential energy cost savings

component layout not only ensures even greater efficiency, but also allows direct access to all service and maintenance points from the front of the unit. This saves both time and money when it comes to servicing.

Perfect partners

CSD and CSDX series rotary screw compressors are the perfect choice for high efficiency compressed air systems in industrial settings. The internal SIGMA CONTROL 2 compressor controller offers numerous communication channels, which allows seamless communication with advanced master controllers, such as KAESER's SIGMA AIR MANAGER, and in-house centralised control systems. This enables simple setup and achieves unprecedented levels of efficiency.

Effective cooling

KAESER's innovative cooling concept features external coolers to provide significant user advantages: Because the ambient air that is drawn in is not "pre-warmed", it provides significantly enhanced cooling performance. Moreover, cooler status can be checked at a glance and cleaning of these compact units couldn't be easier.

Modular design – Impressive performance



Fig.: CSD 125 T SFC

CSD(X) Series

**KAESER quality and efficiency
for every need**



SIGMA PROFILE airend

At the heart of every CSD/CSDX system lies a premium quality airend featuring KAESER's SIGMA PROFILE rotors. Operating at low speed, Kaeser's airends are equipped with flow-optimised rotors for superior efficiency.

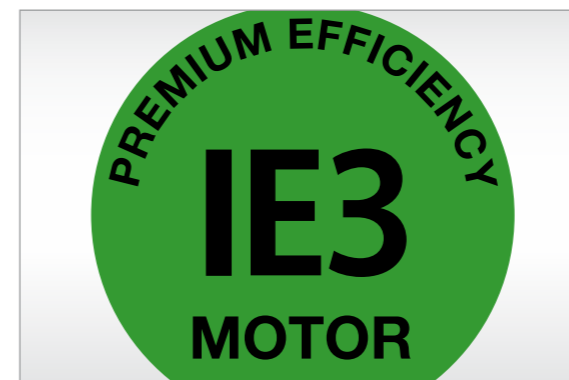

Maximum efficiency: IE3 motors

Kaeser rotary screw airends are powered by IE3 drive motors for maximum performance and reliability. These motors will become obligatory in the EU from 01.01.2015, but users can already enjoy the benefits that these premium efficiency motors have to offer by choosing Kaeser compressors.



SIGMA CONTROL 2

The SIGMA CONTROL 2 ensures efficient control and system monitoring. The large display and RFID reader ensure effective communication and maximum security. Multiple interfaces provide exceptional flexibility. The SD card slot makes updates quick and easy.



Service-friendly savings

Excellent accessibility to all maintenance and service-relevant components minimises maintenance effort and therefore costs. KAESER's newly developed centrifugal separator with electronic condensate drain is fitted as standard.

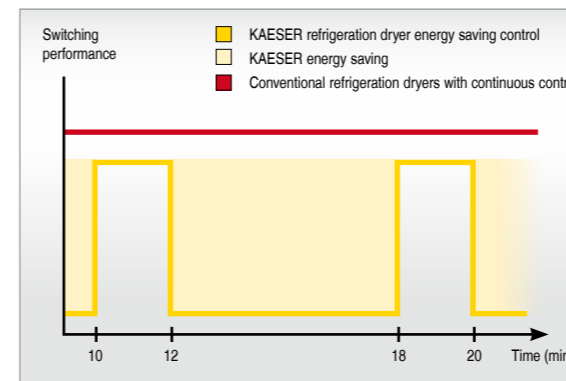

Fig.: CSD 125 T

Lubrication point for drive motor and fan motor

CSD(X) T Series

Premium compressed air quality with integrated refrigeration dryers



Energy-saving control

The integrated refrigeration dryer in CSD(X)-T units provides high-efficiency performance thanks to its energy-saving control. In other words, the dryer is active only when compressed air actually needs to be dried: This approach therefore achieves the required compressed air quality with maximum efficiency.



Optimised dryer performance

Before flowing into the refrigeration dryer, the compressed air from the compressor passes through KAESER's newly developed centrifugal separator which efficiently removes accumulating condensate. This consequently reduces dryer energy consumption.



Dual cooling

Two independent fans and a separate enclosure ensure high thermal reserve for the integrated refrigeration dryer. This allows the required compressed air quality to be reliably maintained at all times even at high ambient temperatures.

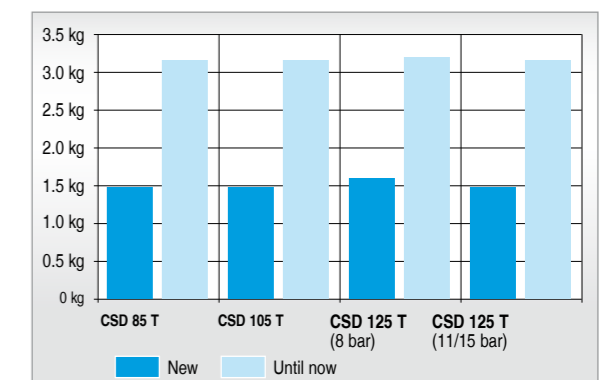

Minimal refrigerant required

The refrigeration dryers in KAESER's new CSD(X)-T units require approximately 50 percent less refrigerant than conventional dryers. This not only saves costs, but is also significantly more environmentally compatible.



Lubrication point for drive motor and fan motor

Fig.: CSDX 165 SFC

CSD(X) SFC Series

Variable speed control perfected

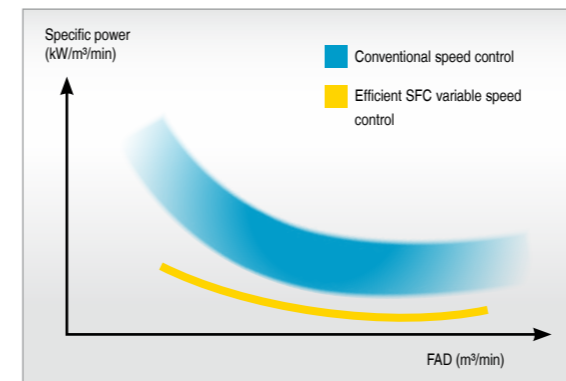

Optimised specific power requirement

In any compressed air installation, it is the variable speed controlled compressor that operates longer than any other unit within the system. CSD(X)-SFC models were therefore built with maximum efficiency in mind and are designed to prevent extreme high speed operation. This saves energy, maximises service life and enhances reliability.



SFC module from Siemens

Siemens frequency converters are used in KAESER's speed controlled compressors for several reasons: They provide seamless communication between the SFC control cabinet and the compressor controller, thereby ensuring maximum efficiency at all times.



Pressure always in view

Operating pressure can be consistently maintained within ± 0.1 bar. In turn, the consequent ability to reduce maximum system pressure also reduces energy costs. The relationship between pressure consistency and speed can be viewed directly on the SIGMA CONTROL 2 display.



Zero Interference:

The SFC control cabinet and SIGMA CONTROL 2 are Class A1 tested and certified as per electromagnetic compatibility regulation EN 55011, both as individual components and as an integrated system.



CSD 105

SIGMA 

Equipment

Complete unit

Ready for operation, fully automatic, super-silenced, vibration damped, all panels powder coated. Can be used in ambient temperatures up to +45°C. Service-friendly design: Motor bearings can be lubricated externally (also applies to fan motor).

Airend

Genuine KAESER single-stage rotary screw airend with SIGMA PROFILE rotors and cooling-fluid injection for optimised rotor cooling. 1:1 direct drive.

Fluid and air flow

Dry-air filter with pre-separation, inlet silencer, pneumatic inlet and vent valves, cooling-fluid separator reservoir with three-stage separator system, pressure release valve, minimum pressure / check valve, thermostatic valve and eco fluid-filter in the coolant circuit,

fluid and compressed air cooler. Speed-controlled fan motor (CSDX), centrifugal separator with electronically-controlled and energy-saving condensate drain for air-loss-free performance. Piping and centrifugal separator made from stainless steel.



Refrigeration dryer ('T' models)

Scroll refrigerant compressor with energy-saving shutdown feature; linked to operational status of the compressor when inactive. Alternatively, continuous operation can be selected on site. With energy-saving condensate drain, minimised refrigerant volume.

Electrical components

Premium efficiency IE3 drive motor with PT-100 coil temperature sensor for motor monitoring, ventilated control cabinet to IP 54, automatic star-delta protection, overload relay, control transformer. SFC version also equipped with frequency converter.

SIGMA CONTROL 2

"Traffic light" LED indicators show operational status at a glance, plain text display, 30 selectable languages, soft-touch keys with icons, fully automated monitoring and control. Selection of Dual, Quadro, Vario, Dynamic and continuous control as standard. Interfaces: Ethernet; additional optional communication modules for: Profibus DP, Modbus, Profinet and Devicenet. SD-card slot for data-logging and updates. RFID reader, web server.

General design

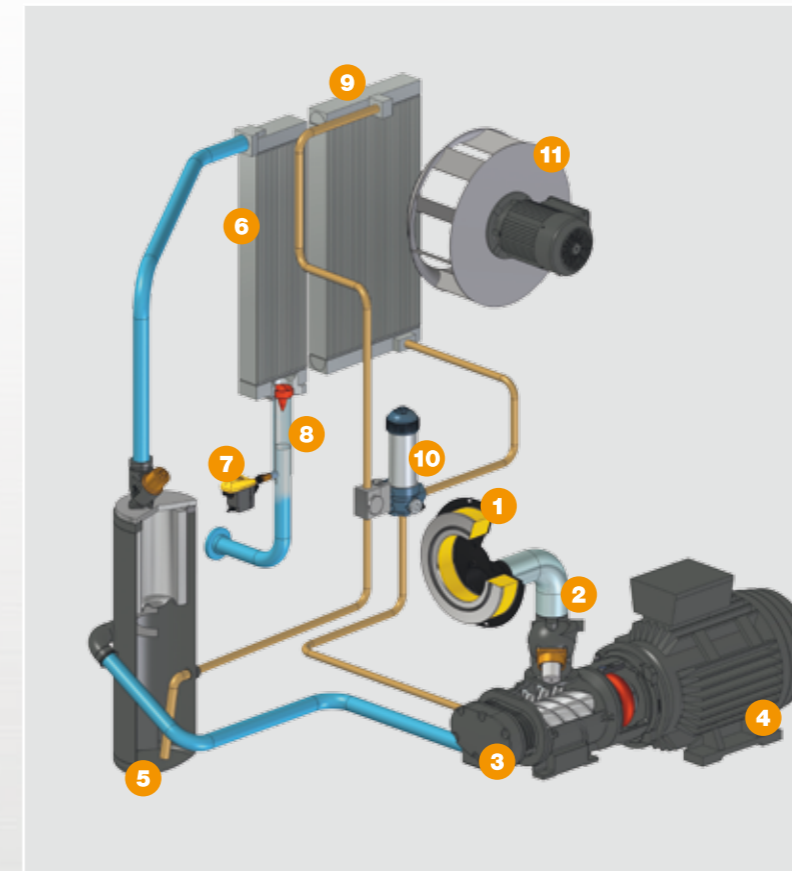

Standard version

- 1 Intake filter
- 2 Inlet valve
- 3 Airend
- 4 Drive motor
- 5 Fluid separator tank
- 6 Air aftercooler
- 7 Centrifugal separator
- 8 Condensate drain (Eco Drain)
- 9 Fluid cooler
- 10 Fluid filter
- 11 Radial fan

Views

	Front view	Rear view	View from left	View from right	3-D view
CSD					
CSD T					
CSD T SFC					
CSDX					
CSDX T					
CSDX T SFC					

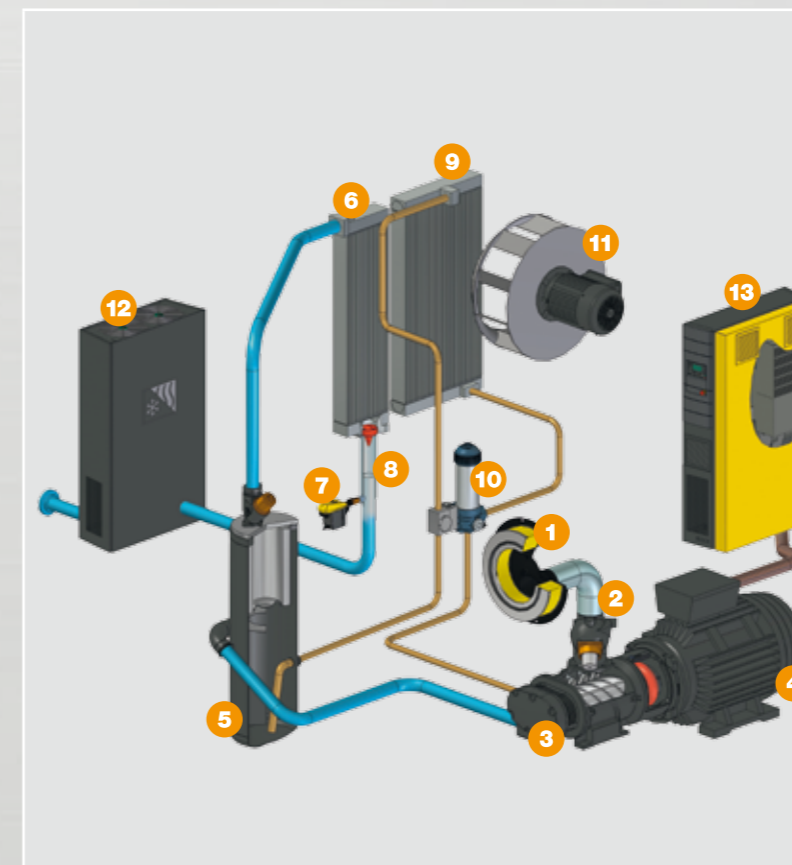

T SFC version

- 1 Intake filter
- 2 Inlet valve
- 3 Airend
- 4 Drive motor
- 5 Fluid separator tank
- 6 Air aftercooler
- 7 Centrifugal separator
- 8 Condensate drain (Eco Drain)
- 9 Fluid cooler
- 10 Fluid filter
- 11 Radial fan
- 12 Integrated refrigeration dryer
- 13 Switching cabinet with integrated SFC frequency converter

Technical Specifications

Standard version

Model	Working pressure	FAD*) overall machine at working pressure	Max. working pressure	Rated engine power	Dimensions W x D x H	Air connection	Sound pressure level **	Weight
	bar	m³/min	bar					
CSD 85	7.5	8.26	8.5	45	1760 x 1110 x 1900	G 2	70	1250
	10	6.89	12					
	13	5.50	15					
CSD 105	7.5	10.14	8.5	55	1760 x 1110 x 1900	G 2	71	1290
	10	8.18	12					
	13	6.74	15					
CSD 125	7.5	12.02	8.5	75	1760 x 1110 x 1900	G 2	72	1320
	10	10.04	12					
	13	8.06	15					
CSDX 140	7.5	13.74	8.5	75	2110 x 1290 x 1950	G 2	71	1830
	10	11.83	12					
	13	9.86	15					
CSDX 165	7.5	16.16	8.5	90	2110 x 1290 x 1950	G 2	72	1925
	10	13.53	12					
	13	11.49	15					

T - Version with integrated refrigeration dryer (refrigerant R 134a)

Model	Working pressure	FAD*) overall machine at working pressure	Max. working pressure	Rated engine power	Refrigeration dryer power consumption **	Dimensions W x D x H	Air connection	Sound pressure level **	Weight
	bar	m³/min	bar						
CSD 85 T	7.5	8.26	8.5	45	0.8	2160 x 1110 x 1900	G 2	70	1410
	10	6.89	12						
	13	5.50	15						
CSD 105 T	7.5	10.14	8.5	55	0.8	2160 x 1110 x 1900	G 2	71	1450
	10	8.18	12						
	13	6.74	15						
CSD 125 T	7.5	12.02	8.5	75	1.1	2160 x 1110 x 1900	G 2	72	1510
	10	10.04	12		0.8				
	13	8.06	15						
CSDX 140 T	7.5	13.74	8.5	75	1.2	2510 x 1290 x 1950	G 2	71	2045
	10	11.83	12						
	13	9.86	15						
CSDX 165 T	7.5	16.16	8.5	90	1.2	2510 x 1290 x 1950	G 2	72	2140
	10	13.53	12						
	13	11.49	15						

SFC - Version with variable speed drive

Model	Working pressure	FAD*) overall machine at working pressure	Max. working pressure	Rated engine power	Dimensions W x D x H	Air connection	Sound pressure level **	Weight
	bar	m³/min	bar					
CSD 85 SFC	7.5	1.95 - 8.08	8.5	45	1760 x 1110 x 1900	G 2	72	1260
	10	1.48 - 6.91	12					
	13	1.07 - 5.92	15					
CSD 105 SFC	7.5	2.19 - 9.85	8.5	55	1760 x 1110 x 1900	G 2	73	1380
	10	1.90 - 8.35	12					
	13	1.36 - 6.88	15					
CSD 125 SFC	7.5	2.84 - 12.00	8.5	75	1760 x 1110 x 1900	G 2	74	1400
	10	2.05 - 10.53	12					
	13	1.79 - 8.75	15					
CSDX 140 SFC	7.5	3.39 - 13.17	8.5	75	2110 x 1290 x 1950	G 2	72	1835
	10	2.81 - 11.33	12					
	13	1.90 - 9.73	15					
CSDX 165 SFC	7.5	3.84 - 15.84	8.5	90	2110 x 1290 x 1950	G 2	73	2025
	10	3.29 - 13.84	12					
	13	2.70 - 11.70	15					

T SFC - Version with variable speed drive and integrated refrigeration dryer

Model	Working pressure	FAD*) overall machine at working pressure	Max. working pressure	Rated engine power	Refrigeration dryer power consumption **	Dimensions W x D x H	Air connection	Sound pressure level **	Weight
	bar	m³/min	bar						
CSD 85 T SFC	7.5	1.95 - 8.08	8.5	45	0.8	2160 x 1100 x 1900	G 2	72	1420
	10	1.48 - 6.91	12						
	13	1.07 - 5.92	15						
CSD 105 T SFC	7.5	2.19 - 9.85	8.5	55	0.8	2160 x 1110 x 1900	G 2	73	1540
	10	1.90 - 8.35	12						
	13	1.36 - 6.88	15						
CSD 125 T SFC	7.5	2.84 - 12.00	8.5	75	1.1	2160 x 1110 x 1900	G 2	74	1590
	10	2.05 - 10.53	12		0.8				
	13	1.79 - 8.75	15						
CSDX 140 T SFC	7.5	3.39 - 13.17	8.5	75	1.2	2510 x 1290 x 1950	G 2	72	2050
	10	2.81 - 11.33	12						
	13	1.90 - 9.73	15						
CSDX 165 T SFC	7.5	3.84 - 15.84	8.5	90	1.2	2510 x 1290 x 1950	G 2	73	2240
	10	3.29 - 13.84	12						
	13	2.70 - 11.70	15						

*) FAD in accordance with ISO 1217: 2009, Annex C: absolute inlet pressure 1 bar (a), cooling- and air inlet temperature 20 °C

**) Noise pressure level as per ISO 2151 and the basic standard ISO 9614-2, tolerance: ± 3 dB (A)

Choose the required grade of treatment according to your field of application:

Air treatment using a refrigeration dryer (pressure dew point +3 °C)

Application examples: Selection of treatment classes to ISO 8573-1 (2010)

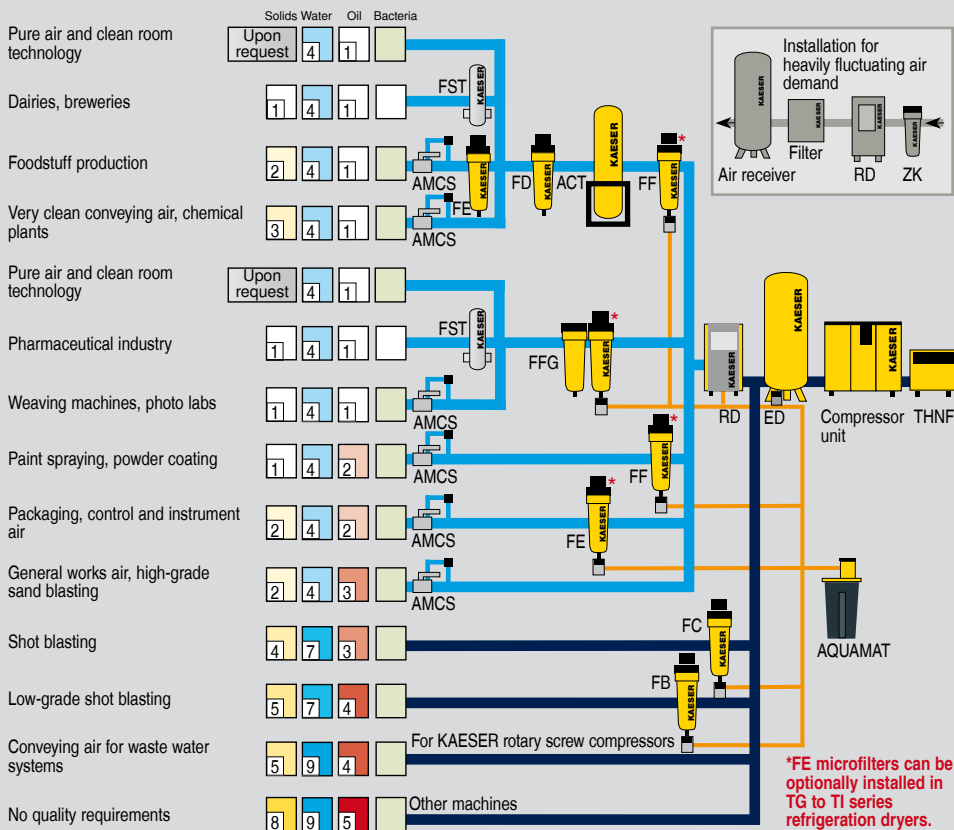

For non frost protected air systems: Compressed air treatment with a desiccant dryer (down to -70 °C pressure dew point)

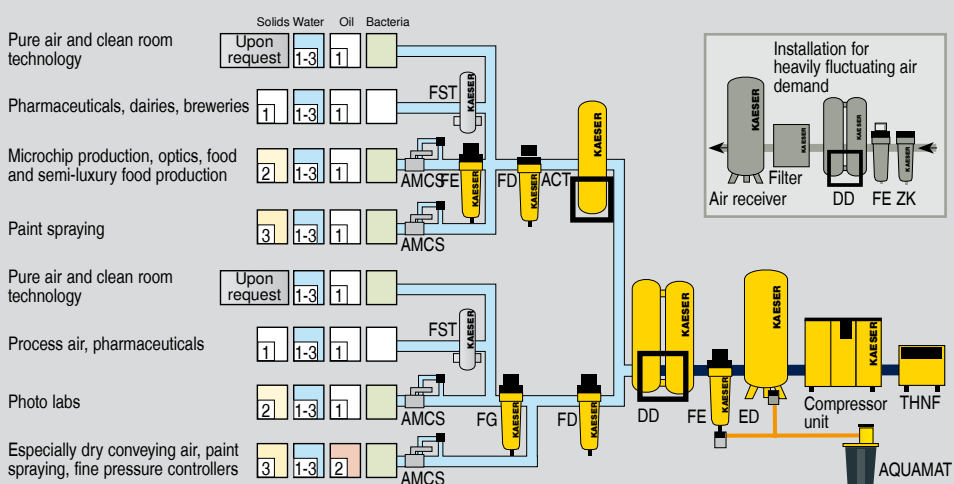

Explanation	
THNF	Bag filter
ZK	Centrifugal separator
ED	ECO DRAIN
FB / FC	Pre-filter
FD	Particulate filter
FE / FF	Microfilter
FG	Activated carbon filter
FFG	Activated carbon and microfilter combination
RD	Refrigeration dryer
DD	Desiccant dryers
ACT	Activated carbon adsorber
FST	Sterile filter, upon request
Aquamat	Aquamat
AMCS	Air-main charging system

Compressed air quality classes to ISO 8573-1(2010):

Solid particles/dust			
Class	max. particle count per m ³ of a particle size with d [µm]*		
	0.1 ≤ d ≤ 0.5	0.5 ≤ d ≤ 1.0	1.0 ≤ d ≤ 5.0
0	e.g. Consult KAESER regarding pure air and cleanroom technology		
1	≤ 20.000	≤ 400	≤ 10
2	≤ 400.000	≤ 6.000	≤ 100
3	Not defined	≤ 90.000	≤ 1.000
4	Not defined	Not defined	≤ 10.000
5	Not defined	Not defined	≤ 100.000
Class	Particle concentration C _p in mg/m ³ **		
6	0 < C _p ≤ 5		
7	5 < C _p ≤ 10		
X	C _p > 10		

Water	
Class	Pressure dew point, in °C
0	e.g. Consult KAESER regarding pure air and cleanroom technology
1	≤ -70 °C
2	≤ -40 °C
3	≤ -20 °C
4	≤ + 3 °C
5	≤ + 7 °C
6	≤ + 10 °C
Class	Concentration of liquid water C _w in g/m ³ **
7	C _w ≤ 0.5
8	0.5 < C _w ≤ 5
9	5 < C _w ≤ 10
X	C _w ≤ 10

Oil	
Class	Total oil concentration (fluid, aerosol + gaseous) [mg/m ³]*
0	e.g. Consult KAESER regarding pure air and cleanroom technology
1	≤ 0.01
2	≤ 0.1
3	≤ 1.0
4	≤ 5.0
X	> 5.0

*) At reference conditions 20 °C, 1 bar(a), 0% humidity